

(TLG123A)

PANEL CIRCUIT INDICATOR

- All Plastic Mold Type
TL□123 : Colored Transparent Lens
TL□124 : Colored Diffused Lens
- Low Drive Current, High Intensity Light Emission.
Recommended Forward Current : $I_F=5\sim 10\text{mA}$ (DC)
- All Plastic Molded Lens, Provides an Excellent ON-OFF Contrast Ratio.
- Fast Response Time, Capable of Pulse Operation.

MATERIALS

PRODUCT NAME	Materials	Light emitting color
TLG123A / TLG124A	GaP	Green
TLY123 / TLY124	GaAsP	Yellow
TLO123 / TLO124	GaAsP	Orange
TLS123 / TLS124	GaAsP	Red
TLUR123 / TLUR124	GaAlAs	
TLR123 / TLR124	GaP	

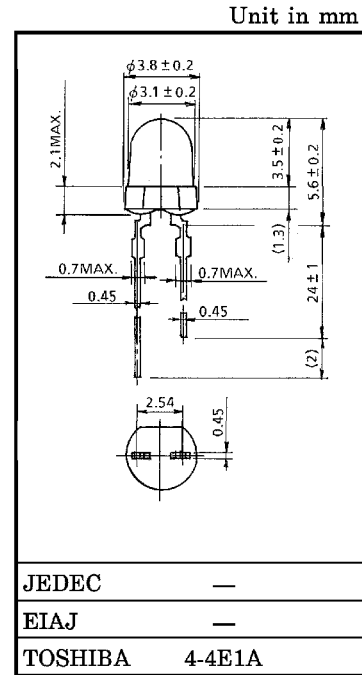

Weight : 0.14g

MAXIMUM RATINGS ($T_a = 25^\circ\text{C}$)

PRODUCT NAME	Forward Current I_F (mA)	Reverse Voltage V_R (V)	Power Dissipation P_D (mW)	Operating Temperature Range T_{opr} ($^\circ\text{C}$)	Storage Temperature Range T_{stg} ($^\circ\text{C}$)
TLG123A / TLG124A	25	4	70	-20~75	-30~100
TLY123 / TLY124	25	4	70	-20~75	-30~100
TLO123 / TLO124	25	4	70	-20~75	-30~100
TLS123 / TLS124	25	4	70	-20~75	-30~100
TLUR123 / TLUR124	25	4	55	-20~75	-30~100
TLR123 / TLR124	20	4	60	-20~75	-30~100

- The information contained herein is presented only as a guide for the applications of our products. No responsibility is assumed by TOSHIBA CORPORATION for any infringements of intellectual property or other rights of the third parties which may result from its use. No license is granted by implication or otherwise under any intellectual property or other rights of TOSHIBA CORPORATION or others.
- TOSHIBA is continually working to improve the quality and the reliability of its products. Nevertheless, semiconductor devices in general can malfunction or fail due to their inherent electrical sensitivity and vulnerability to physical stress. It is the responsibility of the buyer, when utilizing TOSHIBA products, to observe standards of safety, and to avoid situations in which a malfunction or failure of a TOSHIBA product could cause loss of human life, bodily injury or damage to property. In developing your designs, please ensure that TOSHIBA products are used within specified operating ranges as set forth in the most recent products specifications. Also, please keep in mind the precautions and conditions set forth in the TOSHIBA Semiconductor Reliability Handbook.

TLG123A - 1

1996-09-20

TOSHIBA CORPORATION

(TLG123A)

ELECTRO-OPTICAL CHARACTERISTICS (Ta = 25°C)
 123A 123 SERIES (Colored Teapantent Lens)

PRODUCT NAME	EMISSION SPECTRUM			LUMINOUS INTENSITY I _V			FORWARD VOLTAGE V _F			REVERSE CURRENT I _R	
	λ _p	Δλ	I _F	MIN.	TYP.	I _F	TYP.	MAX.	I _F	MAX.	V _R
TLG123A	565	25	10	2.5	10	10	2.15	2.8	20	5	4
TLY123	585	32	10	0.5	5.0	10	2.05	2.8	20	100	4
TLO123	610	35	10	0.5	5.0	10	2.05	2.8	20	100	4
TLS123	635	40	15	4.0	15	15	2.05	2.8	20	100	4
TLUR123	660	25	20	5.0	20	20	1.75	2.2	20	100	4
TLR123	700	100	10	0.5	3.5	10	2.15	2.8	20	5	4
Unit	nm		mA	mcd		mA	V		mA	μA	V

124A 124 SERIES (Colored Lusterless Lens)

PRODUCT NAME	EMISSION SPECTRUM			LUMINOUS INTENSITY I _V			FORWARD VOLTAGE V _F			REVERSE CURRENT I _R	
	λ _p	Δλ	I _F	MIN.	TYP.	I _F	TYP.	MAX.	I _F	MAX.	V _R
TLG124A	565	25	10	0.8	5.0	10	2.15	2.8	20	5	4
TLY124	585	32	10	0.4	4.0	10	2.05	2.8	20	100	4
TLO124	610	35	10	0.4	4.0	10	2.05	2.8	20	100	4
TLS124	635	40	15	2.5	10	15	2.05	2.8	20	100	4
TLUR124	660	25	20	3.0	10	20	1.75	2.2	20	100	4
TLR124	700	100	10	0.4	2.5	10	2.15	2.8	20	5	4
Unit	nm		mA	mcd		mA	V		mA	μA	V

PRECAUTION

Please be careful of the followings.

- Soldering temperature : 260°C MAX. Soldering time : 3s MAX.
 (Soldering portion of lead : up to 2mm from the body of the device)
- If the lead is formed, the lead should be formed at distance of 5mm from the body of the device.
 Soldering shall be performed after lead forming.

TLG123A - 2
1996-09-20
TOSHIBA CORPORATION

(TLG123A)

$I_V - I_F$

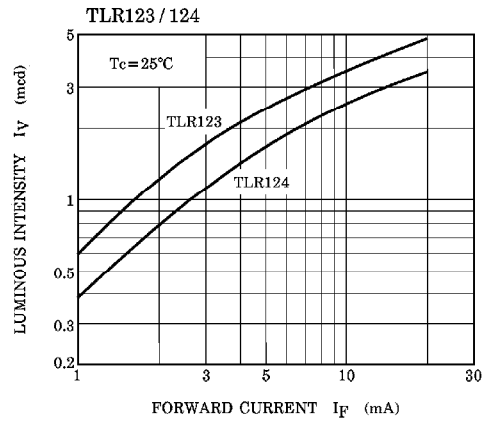
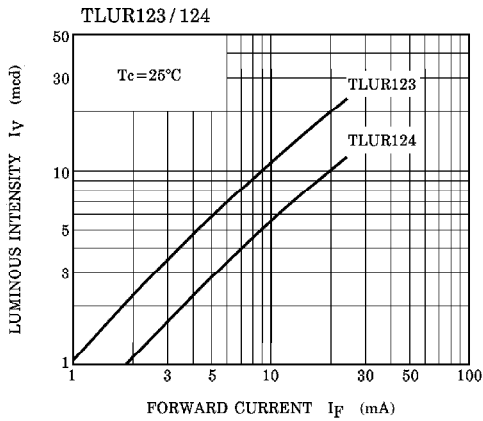
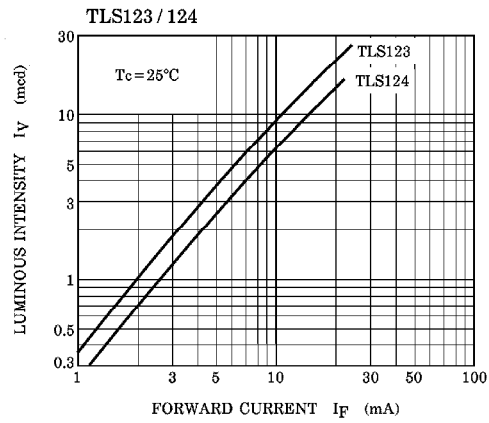
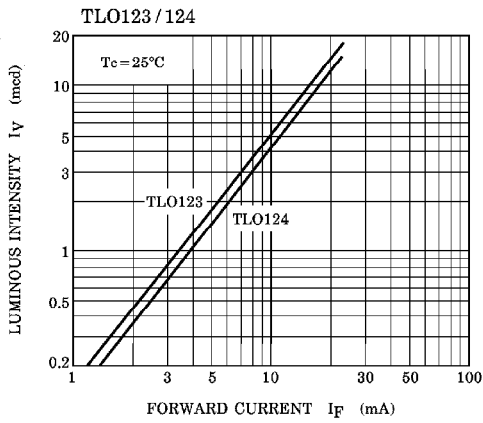
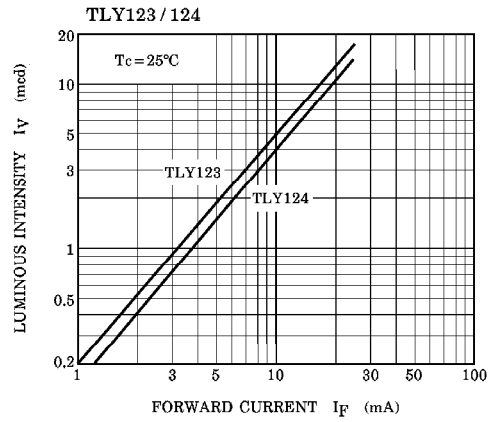
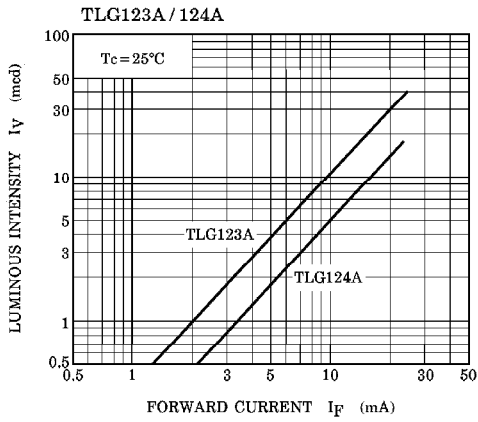

TLG123A - 3
1996-09-20
TOSHIBA CORPORATION

(TLG123A)

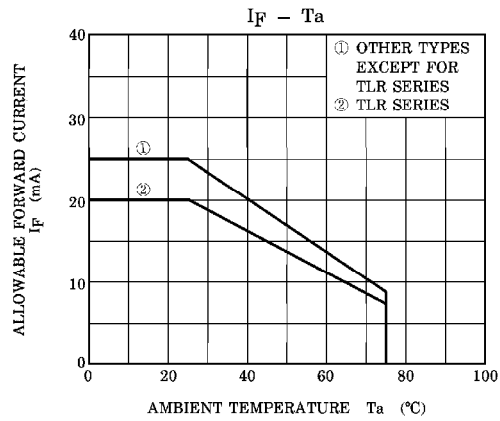
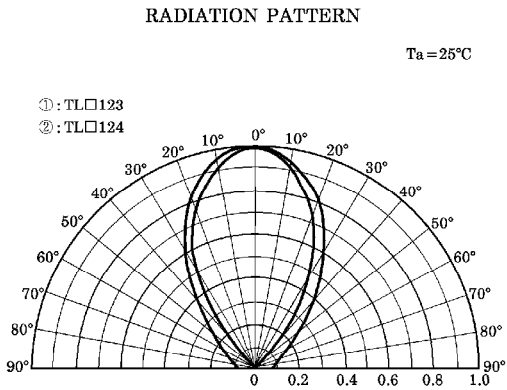
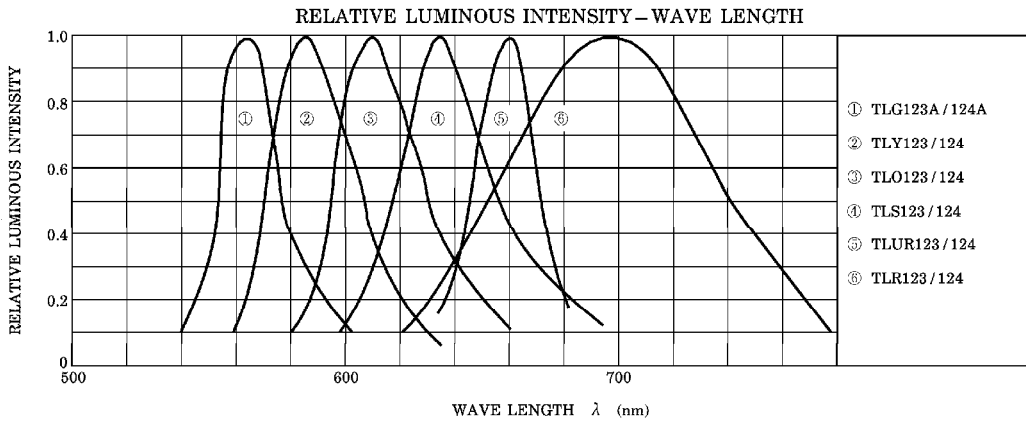
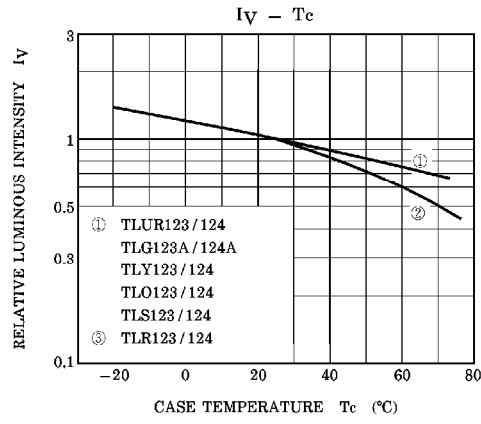
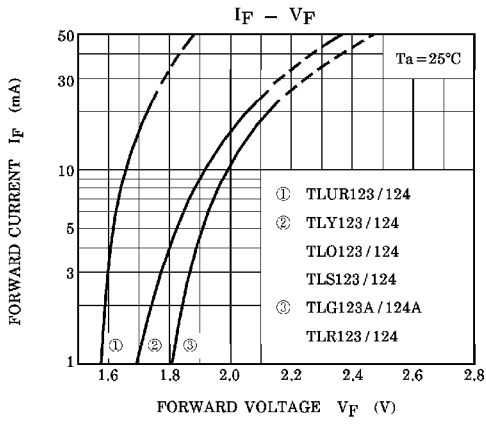

TLG123A - 4*
1996-09-20
TOSHIBA CORPORATION